

ENGINE SYSTEM

- Kubota® D1005-E3BG1-MGM-1
- Diesel fueled
- EPA Tier 4
- 3 cylinder
- .95 L displacement
- Liquid cooled
- Power @ 1,800 rpm – HP (kW):
 - Prime: 11.7 (8.72)
 - Standby: 13.1 (9.77)

Fuel System

- Polyethylene tank – 56.4 gal (213.5 L) usable fuel volume
- Fuel consumption – gal/hr (L/hr):
 - 100% load: 0.67 (2.53)*
- Exterior fill port diameter: 3.5 in (88.9 mm)
- Fuel filter with replaceable element

Cooling System

- Air filter: Dry type cartridge

Lubrication System

- Oil filter: Full flow, spin-on type
- 1,000-hr service interval*

**Results based on engine manufacturer and field test data after 100-hour engine break-in period and may vary based on factors including age and maintenance of equipment, environmental conditions and fuel density. Consult the Owner's Manual for fuel and maintenance recommendations.*

GENERATOR

- 60 Hz engine/generator
- Marathon Electric® brushless
- Up to 6 kW output
- 120/240 VAC, 50/25 A
- ± 6% capacitor voltage regulation

CONTROLS

- Engraved, aluminum punched and anodized control panel
- 4-position key activated switch (off, run, glow, start)
- Digital hour meter
- Automatic low oil/high temperature shutdown system



FLOODLIGHTS

- Four [4] 1,100 watt metal halide
 - Lm/bare bulb: 132,000
 - Lm/fixture: 70,356
 - Total bare bulb lm: 528,000
 - Total fixture lm: 281,424
- Efficiency: 120 LPW
- Coverage: @ 0.5 ft-c: 31,902 ft² (2,954 m²)
- Oval aluminum reflector
- Tempered glass lens
- Silicone gaskets for moisture and dust protection
- Friction disc mounting for tool less positioning
- Individual floodlight On/Off switches
- Internal cabinet light storage

ELECTRICAL SYSTEM

- 30 A start trip breaker (ensures no-load condition exists at start-up)
- Floodlight circuits with sealed 15A breakers
- Ballast Indicator lights
- Convenience receptacles with individual breakers:
 - (1) 120 VAC 20 Amp GFCI duplex outlets (NEMA 5-20R type)
 - (1) 240 VAC, 30 A, twistlock outlet (NEMA L6-30R type)
- 440CCA CCA wet cell battery

MAST

- Wind Rating: 65 mph (105 kph)
- Vertical mast; 25 ft. (7.62 m) maximum extension, 5-section, tubular steel
- Distinctive angle fixture design for consistent light distribution
- Electric winch standard
- 950 lb. (430.91 kg) automatic self-breaking electric winch – easily raises mast vertically
- 359° ground-level rotation with locking system
- Coiled mast cord

ENCLOSURE

- Steel enclosure – 14-gauge
 - UV & fade resistant, high temperature cured, white polyester powder paint
 - 68 dB(A) at 23 ft. (7 m) – prime power
- Stainless steel hinges on doors
- Multi-lingual operating/safety decals
- License plate holder with light
- Manual holder with operating manual
- Equipped with single lifting eye and fork pockets

TRAILER

- Front step platform for easy adjustment of light fixtures
- Removable tongue – 48 in. (1219.20 mm) long
- (4) 2000 lb. (907.18 kg) adjustable leveling jacks – 4 point stance
- All jacks transport and lock in horizontal position for storage

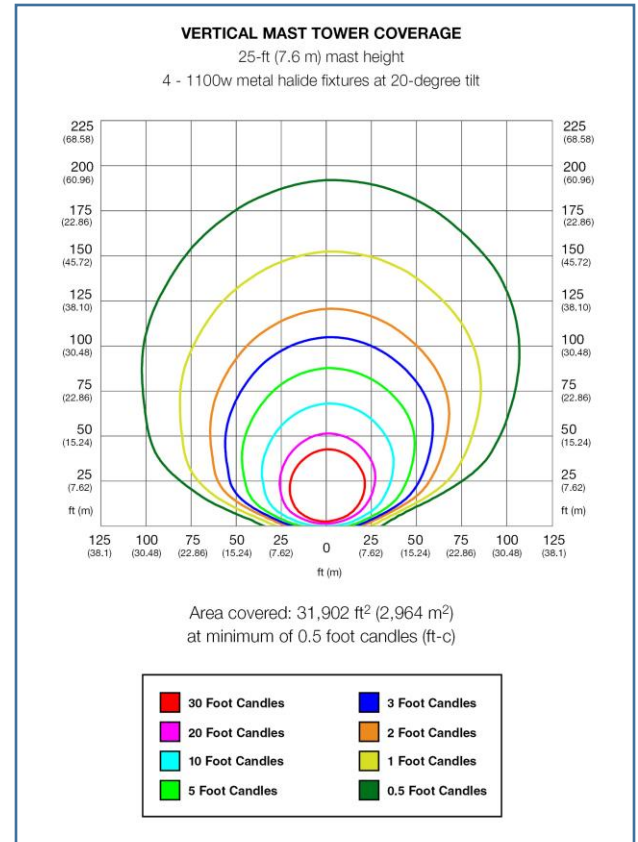

- Side outriggers – 151 in. (3.84 m) span
- Safety chains with spring loaded safety hooks
- Combo hitch: 2 in. (50.8 mm) ball hitch and 2.5 in. (63.5) pintle ring
- Single wall polyethylene fenders
- DOT approved tail, side, brake, and directional lights
 - Recessed rear lights
- 3500 lb. (1588 kg) leaf spring axle
- P205/75R15 – 6 ply
- 68.5 in. (1740 mm) axle span

WEIGHT

- Dry weight: 2018 lbs. (915 kg)
- Operating weight: 2421 lbs. (1098 kg)

DIMENSIONS

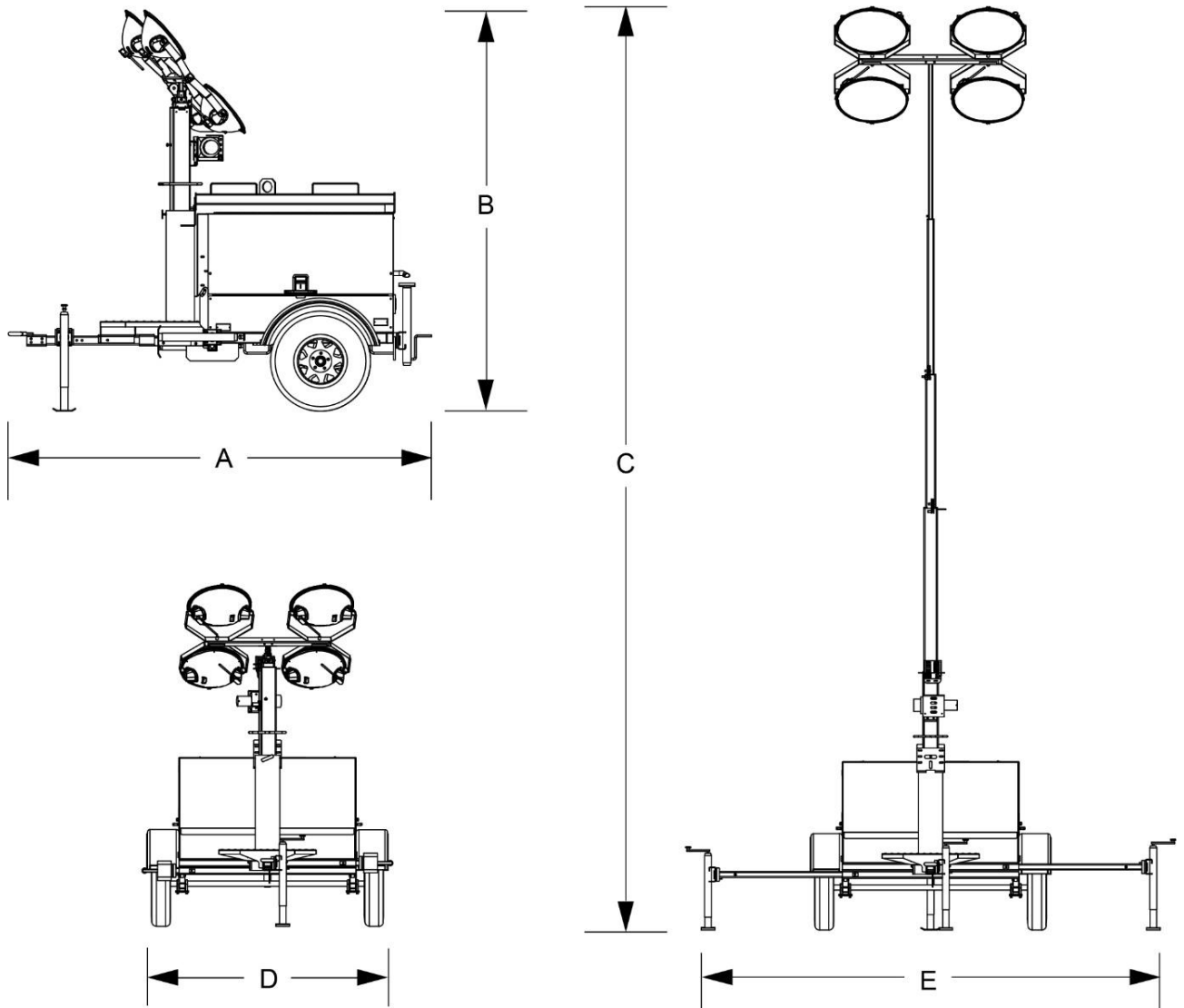

A	B	C	D	E
120 in (3.05 m)	111 in (2.8 m)	25 ft (7.6 m)	79 in (2 m)	153 in (3.89 m)

OPTIONS

- Digital Power Zone Controller
- Cold weather package options
- Canadian Package (CAN)
 - 60/40 coolant
 - Radiator hose heater
 - Heated fuel filter
 - 775CCA AGM sealed battery
 - Liquid containment
- Additional options available. Please contact a sales representative or the factory for current options.

WARRANTY

- 1 Year / Unlimited Hours
- 2 Years / 2000 Hours

CERTIFICATIONS

CSA Certified

FOR MORE INFORMATION

Owner's manual is available at www.generacmobileproducts.com/resources-tools/manuals.